

NIRA fuel- and lubricant hand pumps



NIRA 2, 6B and 9 hand pumps with an aluminium body are durable for industrial use, heavy machinery and HPAC engineering etc, pumps are reliable in hot or cold (non-freezing solutions) and dusty environments - regardless of electricity.



NIRA 2



NIRA 6B



NIRA 9



NIRA PUMPS • SINCE 1919

NIRA fuel- and lubricant hand pumps are suitable for:

- Diesel fuel and with the viton seals also for petrol
- HPAC engineering, filling heat recovery and cooling systems with glycol
 - Filling hydraulic systems
- Dumping and refilling lubricants in machinery and engines

We have nearly 90 years of experience in manufacturing NIRA pumps. Hundreds of thousands installations secure the availability of pumps and spares.
NIRA hand pumps are widely used by leading manufactures of heavy duty machinery in Finland.

For demanding environment reliable NIRA hand pump. Suitable for water as well!



NIRA 2



NIRA 6B

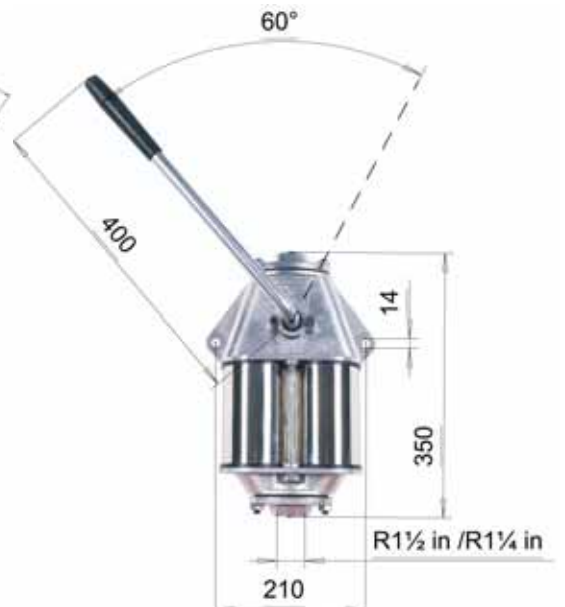

NIRA 9

- Capacity 24 l/min
- Suction height approx 3 m
- Joint for barrel M64 x 4 and R 2"
- 19 mm hosepipe connection
- Weight 1,4 kg

- Capacity 40 l/min
- Suction height approx 8 m, without bottom valve 4 meters
- Pipe joints 3/4" or 1"
- Weight 3,3 kg
- Pressure 1 bar

- Capacity 60 l/min
- Suction height approx 8 m, without bottom valve 4m
- Pipe joints 1 1/4" or 1 1/2"
- Weight 5,8 kg
- Pressure 1 bar



Manufacturer: NIRA PUMPS OY, P.O.BOX 54, 38201 SASTAMALA, FINLAND
Contact: Tel: +358 10 830 6700, fax: +358 10 830 6702, internet: www.nira.fi

